

Firmware datasheet

1 Firmware

This document is the technical datasheet of a communication firmware. It describes the structure, features and interfaces of a loadable communication firmware, running on a netX SoC based device. Each communication firmware consists of several software components. The document lists the technical data and limitations of each component separately. Furthermore 3rd party software components and their licenses are listed in this document.

A Loadable Firmware (LFW) is provided as single binary file (*.nxf, *.nxi) or set of binary files (*.nxi + *.nxe). Each binary, respectively set of binary files, comes with a dedicated firmware datasheet document.

More information with a higher level of details, can be found in various additional documents. Primarily the Dual Port Memory Manuals and the Protocol API Manuals.

1.1 File information

Firmware	EtherNet/IP Adapter firmware
File name	M020H000.nxf
Version	V3.8.0.0

Table 1. File information

1.2 Requirements

For operation, the firmware requires the following hardware environment and parameters.

Requirements	Description
ASIC	netX100
Hardware design	comX Module
2nd Stage Loader	V1.6.0.0 or newer
Device data	Device data provided by the security memory or via DDP - Device Data Provider mailbox service
MAC addresses	MAC 0: EtherNet/IP and IP communication MAC 1: LLDP communication MAC 2: LLDP communication

Table 2. Requirements

2 Firmware interfaces and features

The following figure illustrates the internal structure and all available interfaces of the firmware.

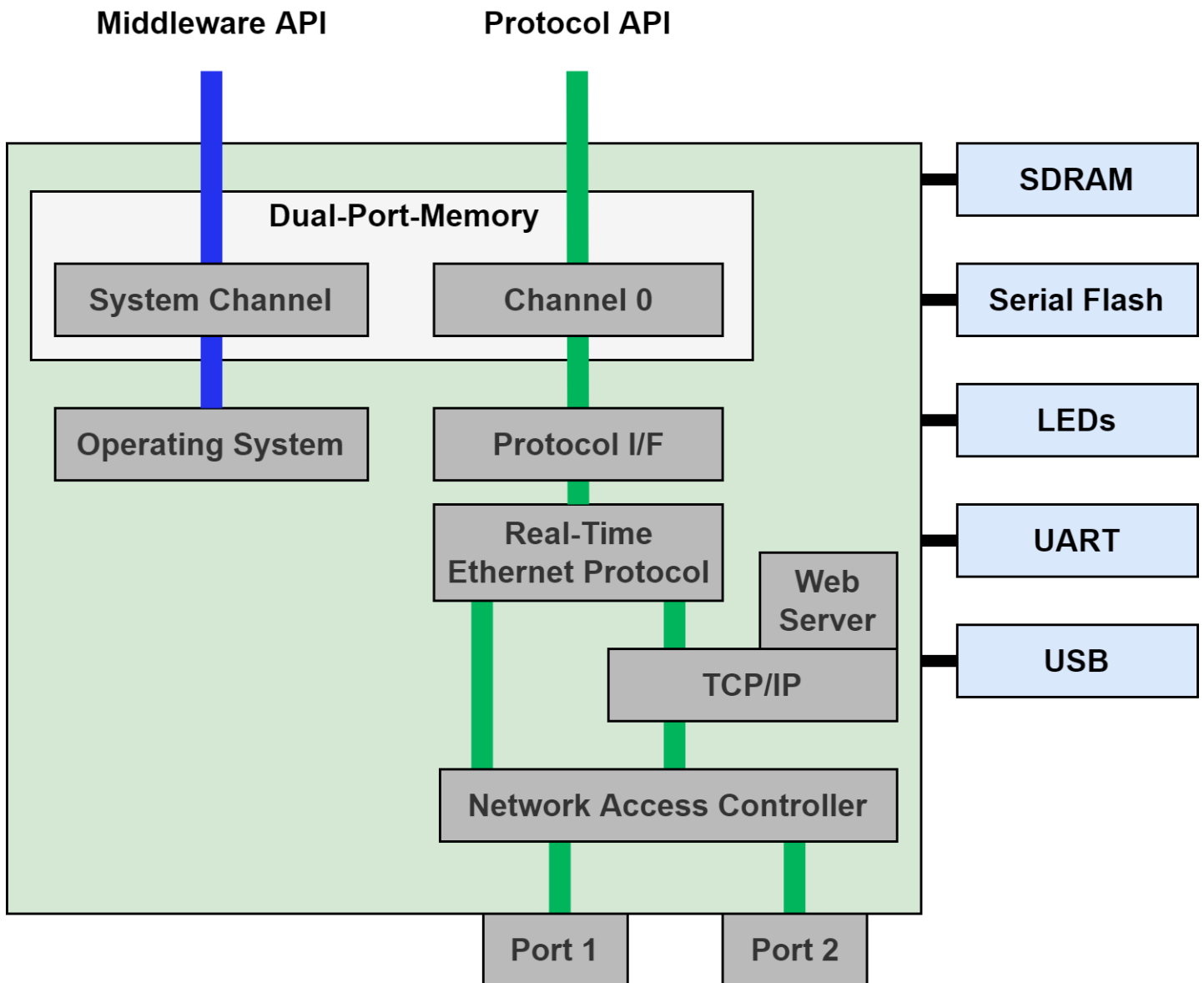

Figure 1. Firmware structure

2.1 Dual-Port-Memory

The Dual Port Memory (DPM), physically located inside the netX SoC, is the central interface between the communication firmware and the user application. It is physically accessed by an external parallel bus, serial SPI interface or an internal data bus. The DPM features a linear address space. The address space is partitioned into several consecutive sections, called "channels". The user application and the communication firmware exchange data, commands and notifications by reading from and writing to the DPM. Each DPM channel is mapped to dedicated firmware functionality and allows usage of respective APIs. You find detailed information about the DPM layout, address spaces and generic services in the Dual Port Memory Manuals.

Channel	API	Manual
System	Middleware API	Manual "netX Dual-Port Memory Interface DPM" and "netX Dual-Port Memory packet-based services"
Channel 0	EtherNet/IP Adapter API	Manual "EtherNet/IP Adapter"

Table 3. Dual-Port-Memory layout

2.2 EtherNet/IP

This firmware offers EtherNet/IP Adapter features and an API to access them.

2.2.1 Technical data

The following technical data apply to EtherNet/IP Adapter features.

Feature	Value
Max. number of input data	504 bytes per assembly instance
Max. number of output data	504 bytes per assembly instance
Max. number of assembly instances	64
IO connection types (implicit)	Exclusive owner Listen only Input only
IO connection trigger types	Cyclic Application triggered Change of state
IO connection RPI (O2T / T2O)	min. 1ms, max. 32,767ms* * Depending on the number of parallel connections and sizes of input and output data.
Explicit messages	Connected and unconnected
Unconnected Message Manager (UCMM)	Supported
Max. number of connections	Target Class 1: 32 Target Class 3: 8 UCMM: 8
Predefined standard objects	Identity Object (0x01) Message Router Object (0x02) Assembly Object (0x04) Connection Manager (0x06) DLR Object (0x47) QoS Object (0x48) TCP/IP Interface Object (0xF5) Ethernet Link Object (0xF6) Time Sync Object (0x43) LLDP Management Object (0x109)
Max. number of user-specific objects	20
Supported features	TCP/IP, UDP/IP DHCP, BOOTP Device Level Ring (DLR) - Media Redundancy Address Conflict Detection (ACD) Quality of Service CIP Reset services - Identity Object Reset service of type 0 and 1 QuickConnect LLDP, SNMP (LLDP MIB) CIP Sync
Ethernet Speed	10 and 100 MBit/s
Ethernet Duplex Modes	Half Duplex, Full Duplex, Auto-Negotiation
Ethernet MDI modes	MDI, MDI-X, Auto-MDIX

Feature	Value
Data transport layer	Ethernet II, IEEE 802.3

Table 4. Technical data

2.2.2 Configuration

- by packets (e.g via Dual-Port-Memory mailbox)
- by database (two files named `config.nxd` and `nwid.nxd`) created by Communication Studio or Sycon.NET

2.2.3 Restrictions and limitations

NOT supported are:

- Tags [common mechanism to address typed PLC data using string identifiers]
- CIP Motion
- CIP Safety

This means the protocol stack itself does not implement the safety application layer. This has to be implemented on the host application side. However, the protocol stack supports all EtherNet/IP features required to build a device that is CIP Safety capable.

2.3 Web server

This firmware has an integrated web server. If desired, the web server can be disabled in firmware tag list via tag "Web server (HTTP) configuration". The web server functionality is described in API Manual "servX HTTP Server - Content Generation".

2.3.1 Technical data

The data below applies to the web server component.

Feature	Description
Integrated modules and dispatch configuration	<ul style="list-style-type: none">■ Firmware Update - Enables uploading a new firmware update file<ul style="list-style-type: none">■ \fwupdate■ Reset - Initiates a netX reset<ul style="list-style-type: none">■ \reset
TCP Port	Default: 80 (http) Can be changed in firmware tag list tag "Web server (HTTP) configuration" (*1)

Table 5. Technical data: Web interface

(*1) Changing "TCP Port" to a port number that is also used by another component inside the firmware, will lead to undefined firmware behavior and shall be avoided.

2.3.2 Restrictions and limitations

- HTTPS is not supported.

2.4 General firmware features

In addition to protocol and component specific features, which are described in other parts of this document, the following general features are provided by this firmware:

Feature	Description
File system	8.3 FAT file system (not fail-safe)
Diagnosis interface	UART Can be disabled via "UART Diagnostics Interface" in tag list.
Diagnosis interface	USB Can be disabled via "USB Diagnostics Interface" in tag list.

Table 6. General firmware features

2.4.1 IP ports used by the firmware and its components

The firmware uses the following ports for IP communication by default:

Protocol	Ports
UDP	2222 (EtherNet/IP Class 0/1), 44818 (EtherNet/IP Class 3 and UCMM), 25383 (Hilscher netident), 68 (DHCP client), 161 (SNMP), 319 and 320 (CIP Sync)
TCP	44818 (EtherNet/IP encapsulation protocol), 80 (http)

Table 7. Summary of IP ports used by firmware

3 Taglist

The Taglist allows users to configure and customize the protocol firmware. The taglist is part of the firmware binary and can be modified by the taglist editor utility.

Name	Description
LED	This tag is used to modify physical LED connection settings in the firmware.
Remanent Data Responsibility	With this tag, you can adjust whether loading and storing of remanent data is entirely performed by the communication firmware or by the host application.
DDP Mode after firmware startup	With this tag, you can control the DDP mode on firmware startup.
Phy enable timeout after firmware startup	With this tag you can specify a maximum delay until Phys will be activated by firmware.
UART Diagnostics Interface	UART interface of netX Diagnostics and Remote Access component.
USB Diagnostics Interface	USB interface of netX Diagnostics and Remote Access component.
Web server (HTTP) configuration	Sets the number of the TCP port that the web server listens on.
LWIP netident behaviour	With this tag, you can adjust whether the firmware shall activate the Hilscher netident protocol, which is build-in in the IP stack, or not.
Ethernet/IP Product Information	When this tag is enabled, the contained CIP Product Information will supercede that from the database or packet configuration.
DLR Protocol	With this tag you can disable Ethernet/IP DLR protocol.

Table 8. Taglists of firmware M020H000.nxf

Note that the Ethernet/IP Product Information tag can only be used in case the protocol stack is configured using a database. For all other configuration methods, this tag is ignored.



4 Third Party Components

Component Name	Component URL	License Type	License URL
newlib	https://developer.arm.com/tools-and-software/open-source-software/developer-tools/gnu-toolchain/gnu-rm/downloads	LGPL	https://sourceware.org/newlib/COPYING.NEWLIB
libc	TBA	TBA	TBA
MD5	https://github.com/ARM-software/patrace/blob/master/thirdparty/md5/md5.c	proprietary "as-is"	https://github.com/ARM-software/patrace/blob/master/thirdparty/md5/md5.c
SNMPv4	SOURCE URL	proprietary "as is"	LICENSE URL
lwIP	https://savannah.nongnu.org/projects/lwip/	BSD	https://lwip.fandom.com/wiki/License

Table 9. Third Party Components